

ARX 40-2C

LIGHT TANDEM VIBRATORY ROLLER

EU Stage V / U.S. EPA Tier 4 Final



WORKING AROUND OBSTRUCTIONS

The Ammann ARX 40-2 C Light Tandem Roller makes it easier to see – and work – near obstructions. It also offers a drum in front and tyres in back to provide both compaction power and the sealing effect of pneumatic rollers. The roller features a new articulating joint that enables quick drum adjustment from in-line to offset configurations, helpful when working close to obstructions. Operators need watch only one drum, knowing the second will be a safe distance from the obstacle. The in-line drum setting is available when it's time for productivity in open spaces.

APPLICATIONS

- Small and medium construction sites
- City roads
- Boardwalks
- City street repairs
- Road maintenance

PRODUCTIVITY

Electronic drive lever

Advanced drive control enables smooth starts and stops during machine operation.

Articulation joint with oscillation

Great manoeuvrability and constant contact with the surface are key factors in achieving high quality compaction.

Sprinkling system

Multi-level filtration system with large water tank for extended intervals between fillings.

ERGONOMICS

Operator platform design

Spacious operator platform with comfortable driver's seat.

Simple & convenient operation control

Dashboard with clear display and intuitive machine control.

Exceptional operator visibility

Perfect all-around machine visibility to maximise safety on the jobsite.

SERVICEABILITY

Tool-free daily inspection

Quick and easy daily inspection.

Maintenance-free parts

Reduce time required for machine maintenance and prevent damage to components.

Service point locations

Service and regular maintenance points are quickly and readily accessible.

MAXIMUM RECOMMENDED COMPACTED LIFT THICKNESS AT OPTIMAL WORKING CONDITIONS

	Sand / gravel	Mixed soils	Silt	Clay	Stabilisation	Asphalt
ARX 40-2C	250 mm (9.8 in)	180 mm (7.1 in)	–	–	120 mm (4.7 in)	100 mm (3.9 in)

AMMANN

TECHNICAL SPECIFICATIONS
ARX 40-2C LIGHT TANDEM VIBRATORY ROLLER
EU Stage V / U.S. EPA Tier 4 Final

DIMENSIONS

A	MACHINE LENGTH	2915 mm (114.8 in)
B	WHEELBASE	2000 mm (78.7 in)
C	MACHINE HEIGHT	2840 mm (111.8 in)
D	MACHINE HEIGHT (FOLDED ROPS)	2150 mm (84.6 in)
E	DRUM WIDTH	1300 mm (51.2 in)
E	TIRE-AXLE WIDTH	1275 mm (50.2 in)
G	MACHINE LENGTH	3000 mm (118.1 in)
H	GROUND CLEARANCE	330 mm (13 in)
H1	SIDE CLEARANCE	605 mm (23.8 in)
I	DRUM DIAMETER	850 mm (33.5 in)
J	DRUM SHELL THICKNESS	18 mm (0.7 in)
K	MACHINE WIDTH (TOTAL)	1385 mm (54.5 in)

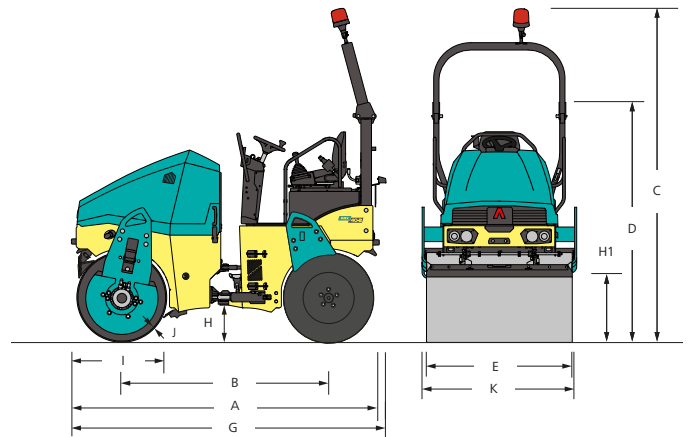

WEIGHT & OPERATING CHARACTERISTICS

OPERATING WEIGHT CECE	4055 kg (8940 lb)
OPERATING WEIGHT MAX.	4355 kg (9600 lb)
STAT. LIN. LOAD	16.5 kg/cm (36 lb/in)
TURNING RADIUS INSIDE	2830 mm (111.4 in)
STEERING / OSCILLATING ANGLE	35/9 ±°

ENGINE

ENGINE TYPE	Kubota D1803-CR-T
EMMISSION CLASS	EU Stage V / U.S. EPA Tier 4 Final
POWER OUTPUT ISO 3046	32.8 kW (44 HP)
CYLINDER / LTR.	3 cyl / 1826 cm ³
NOMINAL SPEED	2400 rpm
TRAVEL SPEED	10 km/h (6.2 MPH)
GRADEABILITY WITH / WITHOUT VIBR.	30 % / 40 %

STANDARD

- Front and rear drive / front vibration
- Pressurised pulse interval sprinkler system
- Anti-adhesive sprinkling circuit
- 2 stage vibratory system
- Control system with emergency stop
- Ammann Vibration Control
- Lateral sliding seat
- Hydraulic test ports
- Off-set into In-line drum setting
- Battery disconnection switch
- On-board diagnostics
- Front/rear rubber bumpers

COMPACTION FORCES

AMPLITUDE I	0.4 mm (0.016 in)
AMPLITUDE II	0.6 mm (0.024 in)
FREQUENCY I	41 Hz (2460 VPM)
FREQUENCY II	55 Hz (3300 VPM)
CENTRIFUGAL FORCE I	42.4 kN (9531.9 lbf)
CENTRIFUGAL FORCE II	53.8 kN (12 094.7 lbf)
CENTRIFUGAL FORCE III	55 kN (12 364.5 lbf)

MISCELLANEOUS

BATTERY / CAPACITY	12/77 V/Ah
WATER TANK	340 l (89.8 gal)
ANTI-ADHESIVE TANK	18 l (4.8 gal)
HYDRAULIC TANK	53.5 l (14.1 gal)
DIESEL FUEL TANK	57 l (15.1 gal)
WHEEL LOAD	481 kg (1060 lb)
NUMBER OF WHEELS	4
TIRE SIZE	10,5/80-16

OPTIONAL EQUIPMENT

- CE-kit with folding ROPS and working lights
- Road lights
- Infrared thermometer
- ACE^{force}
- ATC - Ammann Traction Control
- Reverse alarm
- Additional working lights (ROPS mounted)
- Warning beacon
- Second drive-lever, left
- Arm rests
- Edge-cutter inc. Multi-function lever
- Scrapers tiltable
- Bio-degradable hydraulic oil
- Customer color
- Weather canopy
- Servicelink