

KOMATSU

GD675-6

EU Stage IV Engine

MOTOR GRADER



GD675

ENGINE POWER

165 kW / 221 HP @ 2.100 rpm

OPERATING WEIGHT

16.995 kg
19.220 kg (with ripper)

BLADE LENGTH

4,27 m

Walk-Around

GD675-6



ENGINE POWER

165 kW / 221 HP @ 2.100 rpm

OPERATING WEIGHT

16.995 kg
19.220 kg (with ripper)

BLADE LENGTH

4,27 m



INCREASED PRODUCTIVITY & OUTSTANDING FUEL ECONOMY

High Productivity & Low Fuel Consumption

- Low consumption EU Stage IV engine
- Eco guidance & auto idle stop
- Engine with variable horse power for best power/speed ratio
- Smooth and powerful low-speed operations with torque converter engine stall prevention

KOMTRAX™

- 3G mobile communications
- Increased operational data and fuel savings

First-Class Operator Comfort

- Hexagonal cab for exceptional all-round visibility
- Rear-view camera
- Quiet and spacious operator environment
- Fully adjustable air-suspended seat

Optimised Work Equipment

- Long wheel base and short turning radius
- Versatile moldboard geometry
- Excellent blade controllability with multifunctional control valves
- Blade lift accumulators
- Reinforced blade circle and resin wear plates

Reliability & Maintenance

- Multifunction monitor with troubleshooting function
- Easy access AdBlue® tank
- Hydraulic driven, reversible cooling fan



A maintenance program
for Komatsu customers

Powerful and Environmentally Friendly



Variable engine power

To obtain the right tractive force, engine horse power can be varied between gears. To further fine tune and save fuel the system allows selection of the appropriate mode between Power or Economy mode according to each working condition.

Fuel-efficient hydraulic system

Normally, the variable displacement pump idles at low output. When it senses a load requirement, the pump supplies quick flow and pressure to match the demand. The result is less hydraulic system heat, quick response and lower fuel consumption. Because of the large pump output and proportional flow control function, implement speed is constant regardless of engine speed.

Adjustable idle shutdown

To reduce unnecessary fuel consumption and exhaust emissions, and for lower operating costs, the Komatsu auto idle shutdown automatically turns off the engine after it idles for a set period of time, which can be easily programmed from 5 to 60 minutes. An Eco-gauge and Eco guidance tips on the cab monitor further encourage efficient operations.

GP675-6

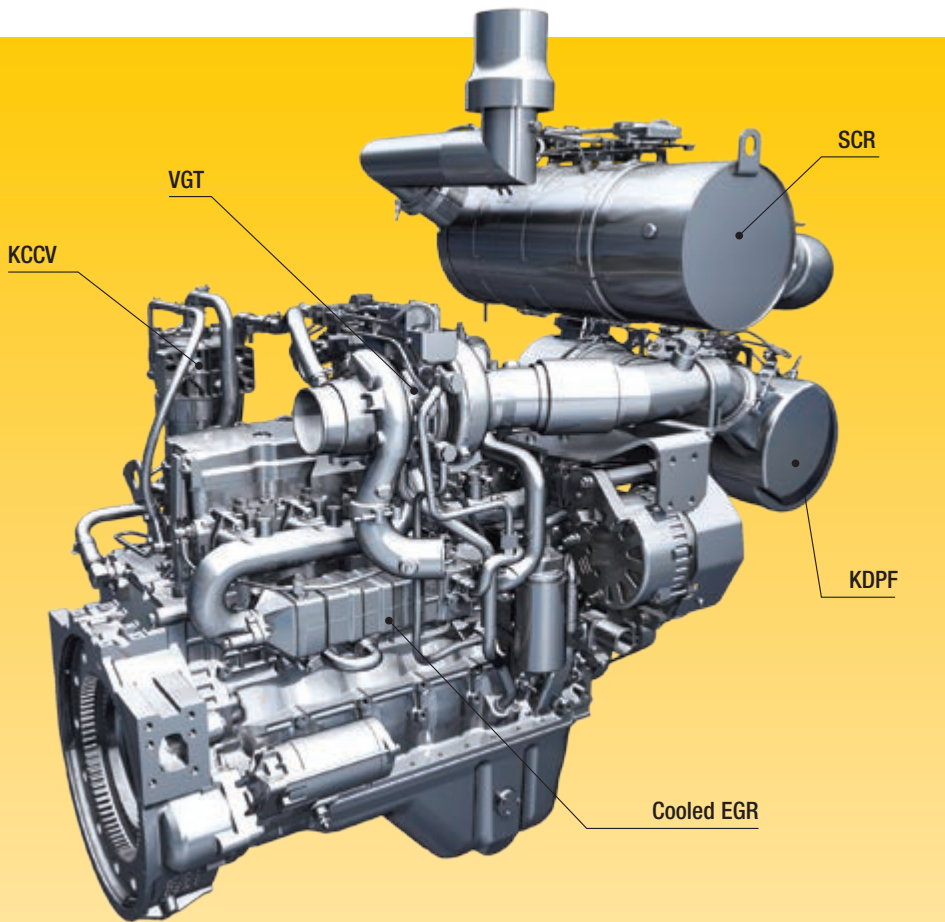

Komatsu EU Stage IV

The Komatsu EU Stage IV engine is productive, dependable and efficient. With ultra-low emissions, it provides a lesser environmental impact and a superior performance to help reduce operating costs and lets the operator work in complete peace of mind.

Heavy-duty aftertreatment

The aftertreatment system combines a Komatsu Diesel Particulate Filter (KDPF) and Selective Catalytic Reduction (SCR). The SCR system injects the correct amount of AdBlue® at the proper rate to break down NOx into water (H₂O) and nontoxic nitrogen gas (N₂). NOx emissions are reduced by 80% vs. EU Stage IIIB engines.

Exhaust Gas Recirculation (EGR)

Cooled EGR is a technology well-proven in current Komatsu engines. The increased capacity of the EGR cooler now ensures very low NOx emissions and a better engine performance.

Komatsu Closed Crankcase Ventilation (KCCV)

Crankcase emissions (blow-by gas) are passed through a CCV filter. The oil mist trapped in the filter is returned back to the crankcase while the filtered gas is returned to the air intake.

High-Pressure Common Rail (HPCR)

To achieve complete fuel burn and lower exhaust emissions, the heavy-duty High-Pressure Common Rail fuel injection system is computer controlled to deliver a precise quantity of pressurised fuel into the redesigned engine combustion chamber by multiple injections.

Variable Geometry Turbo (VGT)

The VGT provides optimal airflow to the engine combustion chamber under all speed and load conditions. Exhaust gas is cleaner, fuel economy is improved while machine power and performance are maintained.

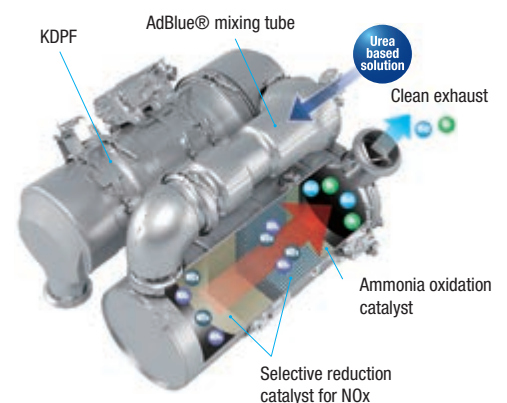

Adjustable idle shutdown



Eco-gauge and Eco guidance



Fuel consumption history

Optimised Work Equipment



Long wheelbase & short turning radius

The long wheel base enables a superior grading with a long blade. On the other hand, the turning radius is short, and provides excellent maneuverability.



Aggressive moldboard angles

Komatsu graders feature a versatile moldboard geometry. Save time and money when pulling ditches by throwing the windrow to the right, not into the roadway - without narrowing the road bed. It's made possible by Komatsu's extraordinary reach and aggressive blade angle. Ample clearance between the heel of the blade and mainframe, even with the toe sharply angled down.



Reinforced blade circle

Durability is improved by the increase in the circle's cross-sectional area, the addition of a drawbar reinforcing plate, and the adoption of a joint bar. Reliability is improved by the reinforced front frame and drawbar. The change to a resin prevents the scratches on the surface of the circle and provides the longer service life.





First-Class Comfort

Quiet and comfortable cab

Operator comfort is essential for safe and productive work. The cab on the GD675-6 is quiet and comfortable, an ideal environment to concentrate on the job. The high capacity climate control system pressurises the cab to keep dust out. A high quality sound-absorbent lining covers the interior to minimise noise levels for the operator.

Superior visibility

Hexangular cab and rear layout side pillar combine for excellent visibility and boost operator's confidence and productivity in all grader applications. Well-positioned blade linkage provides an unobstructed view of the moldboard and front tyres. The fully integrated rear-view camera which can be on all the time ensures a safe working area around the machine.

Fully adjustable air-suspended seat

A comfortable, heavy-duty and fully adjustable heated air-suspended seat is at the centre of the operator's safe and spacious work space. The seat is equipped with fold-up arm rests and a retractable seat belt which is monitored through the machine monitor.





Fully integrated rear-view camera system



The electric throttle control allows the operator to perfectly match the engine speed to working conditions



Set the steering wheel to the most comfortable position

Information & Communication Technology



Lower operating costs

Komatsu ICT contributes to the reduction of operating costs by assisting to comfortably and efficiently manage operations. It raises the level of customer satisfaction and the competitive edge of our products.

Large widescreen monitor

A large user-friendly colour monitor enables safe, accurate and smooth work. Multilingual and with all essential information available at a glance, it features simple and easy-to-operate switches and multifunction keys that provide fingertip access to a wide range of functions and operating information.

Eco guidance

The monitor panel displays instant guidance messages to help promote energy saving, and the Eco-gauge indicates the actual fuel consumption: keep the Eco-gauge in the green zone for better fuel efficiency. To further improve savings, logs can be consulted for operations, Eco guidance and fuel consumption.



Information at a glance: basic dashboard LCD monitor



A multifunction monitor displays and controls a wealth of operational and maintenance information



Eco guidance supports energy saving in real time

KOMTRAX™

The way to higher productivity

KOMTRAX™ uses the latest wireless monitoring technology. Compatible on PC, smartphone or tablet, it delivers insightful and cost saving information about your fleet and equipment, and offers a wealth of information to facilitate peak machine performance. By creating a tightly integrated web of support it allows proactive and preventive maintenance and helps to efficiently run a business.



Knowledge

You get quick answers to basic and critical questions about your machines – what they're doing, when they did it, where they're located, how they can be used more efficiently and when they need to be serviced. Performance data is relayed by wireless communication technology (Satellite, GPRS or 3G depending on model) from the machine to a computer and to the local Komatsu distributor – who's readily available for expert analysis and feedback.

Power

The detailed information that KOMTRAX™ puts at your fingertips 24 hours a day, 7 days a week gives the power to make better daily and long-term strategic decisions – at no extra cost. Problems can be anticipated, maintenance schedules customised, downtime minimised and machines kept where they belong: working on the jobsite.

Convenience

KOMTRAX™ enables convenient fleet management on the web, wherever you are. Data is analysed and packaged specifically for effortless and intuitive viewing in maps, lists, graphs and charts. You can foresee eventual maintenance issues and required spare parts, and troubleshoot a problem before Komatsu technicians arrive on site.



Easy Maintenance



Easy access to service points

Large doors give a convenient access to engine, filters and radiator. Refueling from ground level is safe and comfortable.



AdBlue® tank

For simple access, the AdBlue® tank is installed at ground access level and is equipped with a sight gauge to prevent spillage or overflow.



Komatsu CARE™

Komatsu CARE™ is a maintenance program that comes as standard with your new Komatsu machine. It covers factory-scheduled maintenance, performed with Komatsu Genuine parts by Komatsu-trained technicians. Depending on your machine's engine, it also offers extended coverage of the Komatsu Diesel Particulate Filter (KDPF) or the Komatsu Diesel Oxidation Catalyst (KDOC), and of the Selective Catalytic Reduction (SCR). Please contact your local Komatsu distributor for terms and conditions.



Basic maintenance screen

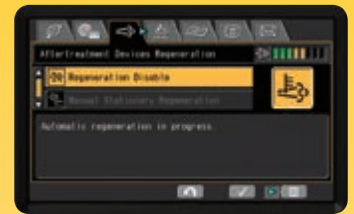

Aftertreatment regeneration screen



AdBlue® level guidance

Reversible radiator fan

By a touch on the monitor panel, the radiator can be cleaned easily with a reversible, hydraulically driven cooling fan. A clean radiator reduces fuel consumption and increases overall machine performance.



Specifications

ENGINE

Model	Komatsu SAA6D107E-3	
Type	Common rail direct injection, water-cooled, emissionised, turbocharged, after-cooled diesel	
No. of cylinders	6	
Bore x stroke	107 x 124 mm	
Displacement	6,69 l	
Fan drive type	Hydraulic, reversible	
Engine power		
(Power mode ISO 14396)		
Gear 1-3	137 kW / 183 HP @ 2.000 rpm	
Gear 4-6	151 kW / 203 HP @ 2.000 rpm	
Gear 7-8	165 kW / 221 HP @ 2.100 rpm	
(Economy mode ISO 14396)		
Gear 1-6	137 kW / 183 HP @ 2.000 rpm	
Gear 7-8	165 kW / 221 HP @ 2.100 rpm	
(Power mode SAE J1349)		
Gear 1-3	135 kW / 180 HP @ 2.000 rpm	
Gear 4-6	150 kW / 200 HP @ 2.000 rpm	
Gear 7-8	163 kW / 218 HP @ 2.100 rpm	
(Economy mode SAE J1349)		
Gear 1-6	135 kW / 180 HP @ 2.000 rpm	
Gear 7-8	163 kW / 218 HP @ 2.100 rpm	
Max. torque / engine speed	941 Nm / 1.450 rpm	
Torque rise	30%	

TRANSMISSION AND TORQUE CONVERTER

Type	Full power shift transmission with integral free wheeling stator torque converter and lock-up
------	---

MAX. TRAVEL SPEEDS

	Forward	Reverse
1st	3,4 km/h	4,5 km/h
2nd	5,0 km/h	9,2 km/h
3rd	7,0 km/h	20,3 km/h
4th	10,2 km/h	40,3 km/h
5th	15,4 km/h	-
6th	22,3 km/h	-
7th	30,6 km/h	-
8th	44,3 km/h	-

ENVIRONMENT

Engine emissions	Fully complies with EU Stage IV exhaust emission regulations
Noise levels	
LwA external	106 dB(A) (2000/14/EC Stage II)
LpA operator ear	75 dB(A) (ISO 6396 dynamic test)
Vibration levels (EN 12096:1997)	
Hand/arm	$\leq 2,5 \text{ m/s}^2$ (uncertainty K = 1,36 m/s ²)
Body	$\leq 0,5 \text{ m/s}^2$ (uncertainty K = 0,17 m/s ²)
Contains fluorinated greenhouse gas HFC-134a (GWP 1430).	
Quantity of gas 1,2 kg, CO ₂ equivalent 1,72 t	

TANDEM DRIVE

Oscillating welded box section	520 mm x 202 mm
Side wall thickness	
Inner	22 mm
Outer	19 mm
Wheel axle spacing	1.525 mm
Tandem oscillation	11° forward, 13° reverse

FRONT AXLE

Type	Solid bar construction welded steel sections
Ground clearance at pivot	620 mm
Wheel lean angle, right or left	16°
Oscillation, total	32°

REAR AXLE

Type	Alloy steel, heat treated, full floating axle with lock/unlock differential
------	---

WHEELS, FRONT AND REAR

Bearings	Tapered roller
Tyres	17.5R25, tubeless
Tyre rims (demountable)	13" one-piece rims

STEERING SYSTEM

Type	Hydraulic power steering providing stopped engine steering meeting ISO 5010
Minimum turning radius	7,4 m
Maximum steering range	49°
Articulation	25°

BRAKE SYSTEM

Service brake	Foot operated, sealed oil disc brakes, hydraulically actuated on four tandem wheels
Parking brake	Manually actuated, spring applied, hydraulically released caliper

FRAME

Front frame structure	
Height	300 mm
Width	300 mm
Side	16 / 32 mm
Upper, Lower	25 mm

Specifications

CIRCLE

Single piece rolled ring forging. Six circle support shoes with replaceable wear surface. Circle teeth hardened on front 180° of circle

Diameter (outside)	1.530 mm
Circle reversing control hydraulic rotation	360°

MOLDBOARD

Hydraulic power shift fabricated from high carbon steel. Includes replaceable metal wear inserts, cutting edge and end bits. Cutting edge and end bits are hardened.

Dimensions	4.270 × 660 × 25 mm
Arc radius	432 mm
Cutting edge	152 × 16 mm
Replaceable/ Reversible side edges	156 × 16 × 456 mm
Blade pull	
Base GVW	10.100 kg
With ripper GVW	10.980 kg
Blade down pressure	
Base GVW	6.940 kg
With ripper GVW	8.400 kg

BLADE RANGE

Moldboard side shift	
Right	820 mm
Left	820 mm
Maximum shoulder reach outside rear tyres (frame straight)	
Right	2.300 mm
Left	2.300 mm
Maximum lift above ground	480 mm
Maximum cutting depth	615 mm
Maximum blade angle, right or left	90°
Blade tip angle	40° forward, 5° backward

HYDRAULIC SYSTEM

Load-sensing closed center hydraulics with variable displacement piston pump. Short stroke/low effort direct acting control valves with preselected maximum flow setting to each function. Double acting anti-drift check valves on blade lift, tip, circle shift, articulation, and leaning wheels.

Output (at rated speed)	200 l/min
Standby pressure	3,4 MPa / 35 kg/cm ²
Max. system pressure	20,6 MPa / 210 kg/cm ²

RIPPER

Ripping depth, maximum	425 mm
Ripper shank holders	5
Ripper shank holder spacing	534 mm
Penetration force	9.390 kg
Pryout force	17.600 kg
Machine length increase, beam raised	690 mm

OPERATING WEIGHT

Includes 17.5R24 tyres, 4,3 m moldboard, lubricants, coolant, full fuel tank and operator

Total	16.995 kg
On rear wheels	12.710 kg
On front wheels	4.360 kg
Front push block – Total	+ 1.180 kg
On rear wheels	- 114 kg
On front wheels	+ 1.219 kg
Front dozer blade – Total	+ 920 kg
On rear wheels	- 119 kg
On front wheels	+ 964 kg
Scarifier, middle – Total	+ 805 kg
On rear wheels	+ 107 kg
On front wheels	+ 623 kg
Ripper – Total	+ 1.042 kg
On rear wheels	+ 1.389 kg
On front wheels	- 347 kg

SERVICE REFILL CAPACITIES

Fuel tank	390 l
AdBlue® tank	37 l
Cooling system	30 l
Crank case	23 l
Transmission	45 l
Final drive	17 l
Tandem housing (each)	57 l
Hydraulic system	69 l
Circle reverse housing	7 l

DRAWBAR

A-shaped, u-section press formed and welded construction for maximum strength with a replaceable drawbar ball.

Drawbar frame	210 × 22 mm
---------------	-------------

FRONT DOZER BLADE

Dimensions (width × height)	2.500 mm × 860 mm
Max. lifting height	565 mm
Max. digging depth	138 mm

SCARIFIER

Middle, V-type	
Working width	1.430 mm
Scarifying depth, maximum	190 mm
Scarifier shank holders	11
Scarifier shank holders spacing	138 mm
Rear	
Working width	2.186 mm
Scarifying depth, maximum	165 mm
Scarifier shank holders	9
Scarifier shank holders spacing	267 mm

DIMENSIONS

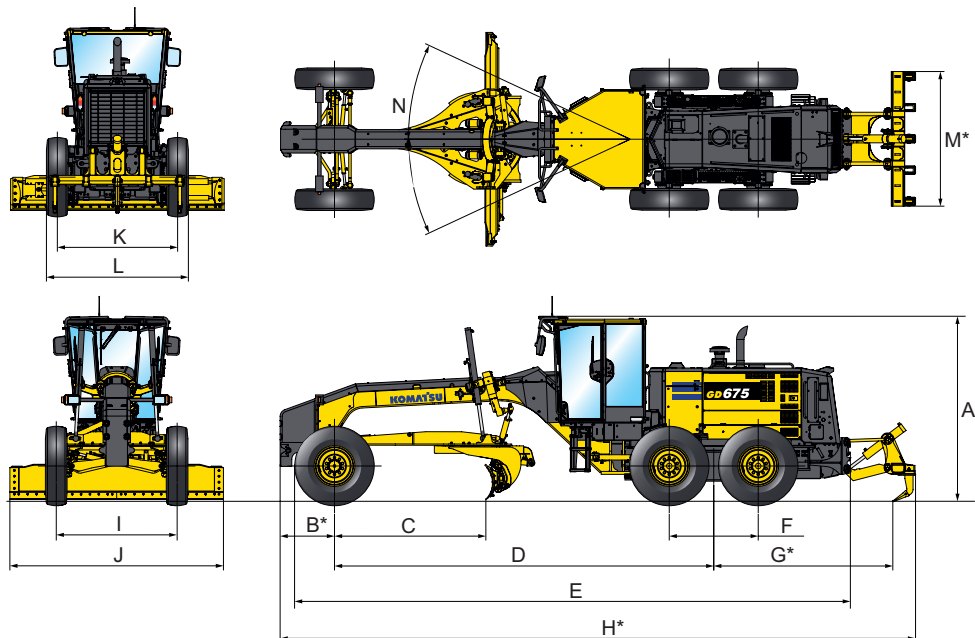

	Type of tyres	17.5R25 XTLA	14.00R34 VUT
A	Height: Low profile cab	3.200 mm	3.200 mm
B*	Center of front axle to counterweight (pusher)	930 mm	930 mm
C	Cutting edge to center of front axle	2.580 mm	2.580 mm
D	Wheelbase to center of tandem	6.495 mm	6.495 mm
E	Front tyre to rear bumper	9.510 mm	9.510 mm
F	Tandem wheelbase	1.525 mm	1.525 mm
G*	Center of tandem to back of ripper	3.065 mm	3.065 mm
H*	Overall length – with front push block + ripper	10.875 mm	10.875 mm
	Overall length – with front dozer blade + ripper	11.400 mm	11.400 mm
I	Tread (front)	2.170 mm	2.070 mm
J	Width of standard moldboard	4.270 mm	3.660 mm
K	Tread (rear)	2.160 mm	2.060 mm
L	Width over tyres	2.630 mm	2.485 mm
M*	Ripper beam width	2.305 mm	2.305 mm
N	Articulation, left or right	25°	25°

* optional

Standard and Optional Equipment

ENGINE AND RELATED PARTS

Komatsu SAA6D107E-3 turbocharged common rail direct injection diesel engine	●
EU Stage IV compliant	●
Alternator 24 V/90 A	●
Batteries 2 × 12 V/140 Ah	●
Cooling fan, hydrostatic driven with reversing function	●
Fuel pre-filter	●
Locks, filter caps and covers	●
Cyclone type air cleaner	●
Alternator 24 V/140 A	○

TRANSMISSION AND BRAKES

Automatic powershift transmission	●
Torque converter with lock-up	●
Engine stall prevention function	●
Transmission under guard	●
Fully hydraulic brake system	●
Differential lock/unlock	●

SERVICE AND MAINTENANCE

Dry type air cleaner, double element with dust indicator and evacuator	●
Multifunction video compatible colour monitor with Equipment Management and Monitoring System (EMMS) and efficiency guidance	●
Water separator	●
KOMTRAX™ – Komatsu wireless monitoring system (3G)	●
Komatsu CARE™ – a maintenance program for Komatsu customers	●
Tool kit	●

CABIN

Heated air-suspended seat: fabric, reclining, high backrest	●
Seat belt with visible alert	●
Air conditioner	●
Radio	●
Auxiliary input (MP3 jack)	●
2 × 12 Volt power supply (120 W)	●
1 × 24 Volt power supply	●
Viscous cab mounts	●
Wiper front and rear window	●
Wipers doors	●
Rear-view mirror (inside cab)	●
Heated rear window	●
Sun visor (rear)	●
Cup holder	●
Lunch box holder	●

SAFETY EQUIPMENT

Steel cab, meets ISO 3471 and SAE J1040, APR88 ROPS standards, as well as ISO 3449 FOPS standards	●
Back-up alarm	●
Warning horn	●
Rear-view camera system	●
Rear-view mirrors	●

LIGHTING SYSTEM

Working lights: 4 front and 2 rear lights	●
4 working lights, cab-mounted, front	●
Rotating beacon	○

HYDRAULIC SYSTEM

Closed-centre load sensing (CLSS) hydraulic system	●
10 section hydraulic control valve	●
Anti-shock accumulators for blade lift	●
Drawbar-mounted circle, 360° rotation, hydraulic blade lift and circle side shift	●
Circle slip clutch	●
Hydraulics for ripper	●

CHASSIS AND TYRES

Heavy-duty axles	●
Tyres 17.5R25	●
Tyres 14.00R24	○

ATTACHMENTS

Front blade	○
Additional pusher plate	○
Scarifier, assembly, 11-shank type	○
Multishank parallelogram ripper	○

MOLDBOARD

Moldboard 4.270 mm × 660 mm × 25 mm with replaceable end bits, through hardened cutting edges 152 mm × 16 mm, hydraulic blade side shift and hydraulic tilt with anti-drift check valves. Maximum moldboard angle position 90° right & left	●
Moldboard 3.660 mm × 660 mm × 25 mm with replaceable end bits, through hardened cutting edges 152 mm × 16 mm, hydraulic blade side shift and hydraulic tilt with anti-drift check valves. Maximum moldboard angle position 90° right & left	○

Further equipment on request

- standard equipment
- optional equipment

Your Komatsu partner:

KOMATSU

**Komatsu Europe
International N.V.**

Mechelsesteenweg 586
B-1800 VILVOORDE (BELGIUM)
Tel. +32-2-255 24 11
Fax +32-2-252 19 81
www.komatsu.eu

EENSS20153 07/2017

KOMATSU is a trademark of Komatsu Ltd. Japan.

Printed in Europe – This specification sheet may contain attachments and optional equipment that are not available in your area.
Please consult your local Komatsu distributor for those items you may require. Materials and specifications are subject to change without notice.
AdBlue® is a registered trademark of Verband der Automobilindustrie e.V.

CD675-6